

SE/HP-118-AA (COMBINED HAND PUMP/ELECTRIC STACKER WITH ADJUSTABLE LEGS & FORKS)

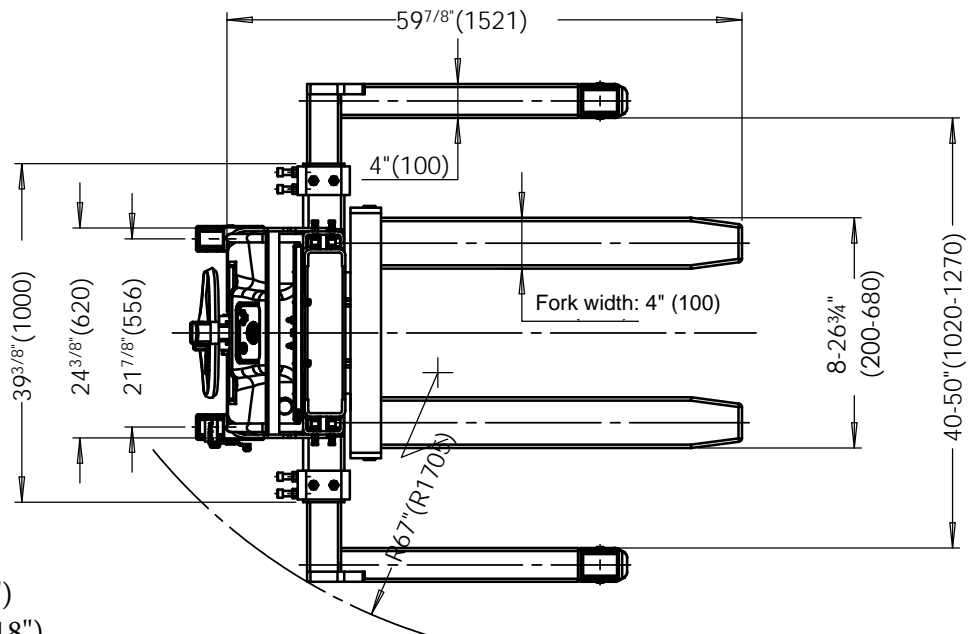
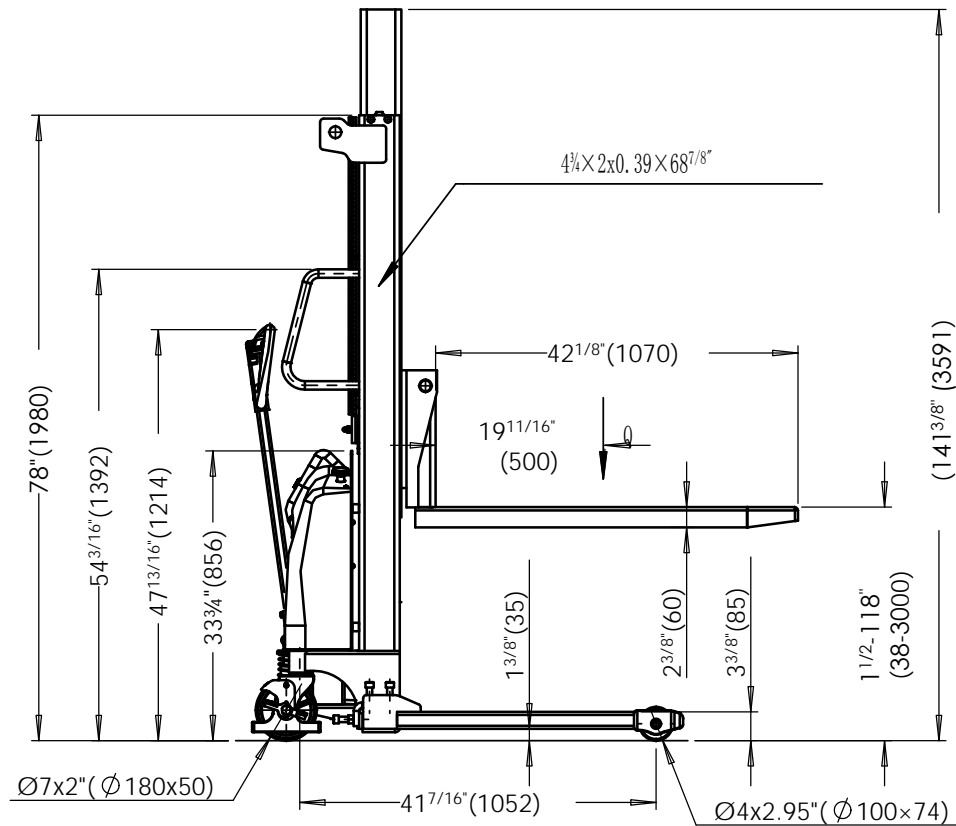

Specifications:

Model # SE/HP-118-AA

Capacity: 2,000 lbs. (0-63")

Capacity: 1,500 lbs. (63-118")

Lift Height: 118"

Lowered Height: 1¹/₂"

Adjustable forks and adjustable legs

Overall Mast Height: 72³/₄"

Lift Motor: DC 24V/1.3KW

Battery: 2x12V/40Ah

Battery Charger: 24V/10amp

Raise time loaded: 1.67"/sec

Raise time unloaded: 2.33"/sec

Downtime loaded: 4.76"/sec

Downtime unloaded: 2.8"/sec

VESTIL MANUFACTURING CORP.	
Model:	SE/HP-118-AA
Description:	Electric/Hydraulic Combination Stacker with Adjustable legs & Forks
Design:	T.M. Date: 11/22/2016